



Sanitary Pressure Gauges Product Data / Specifications



Tri-Clover 3A-approved pharmaceutical and sanitary pressure gauges are designed and engineered to meet the most stringent requirements of the pharmaceutical, biotech, food, beverage and dairy industries. Stem-mounted and back-mounted models are available.

- Available in 2", 2½", 3½" and 4½" dial sizes
- FDA-approved 316L stainless steel wetted parts are crack and crevice free for ultimate purity
- All welded 316 stainless steel bourdon tube
- 3A compliance to standard 74-00
- 300 series stainless steel case and ring
- Polycarbonate window material for all sizes
- Easy to install with low profile and no exposed threads
- Accurate at 70°. Temperature error of $\pm 0.16\%$ per 10° F (approximately 5° C) change
- 20 Ra electropolished diaphragm surface
- Can handle CIP or SIP temperatures to 270° F (132° C)
- Autoclavable*
- USP-grade (food grade) glycerin filled case and base
 - absorbs vibration
 - contributes to longer life
 - helps make gauge easier to read
 - (Case fill not available on 2" dial)
- Available with ¾", 1½" or 2" sanitary connections
- Pressure ranges from 0 to 600 PSI (0 to 42 kg/cm²)
- External zero adjust standard on 3½" dial size
- Accuracy
 - 2½", 3½" and 4½" dial size:
 - 1.5% F.S. for pressure ranges 100 PSI and above
 - 2.0% F.S. for ranges below 100 PSI
 - 2" dial gauges:
 - 2% upscale, up to 5% downscale for ranges 60 PSI and above
 - 3% upscale, up to 5% downscale for ranges below 60 PSI
- Combination English and Metric scale

Tri-Clover pressure gauges are available in stem-mounted (vertical) or back-mounted (horizontal) configurations.

**It is recommended that the gauge case be drained of fill liquid prior to autoclave or sterilization.*

Sanitary Pressure Gauges

Ordering Information

The following example describes the correct ordering sequence for a gauge with: 2½" dial size, horizontal (center back) mounting, pressure range of 0 to 160 psig, glycerin filling, 2" connection fitting.

Example:

54 - 28B - N - 5 - G - 2"

Gauge Size	Gauge	Dial Size	Configuration	Pressure Range	Base Fluid Filling	Connection Fitting
2"	54	29B	N	2 to 6	Glycerin	¾"
2½"	54	28B	N	1 to 7	Glycerin	1½" or 2"
3½"	54	60B	N	1 to 7	Glycerin	1½" or 2"
4½"	54	30B	N	1 to 7	Glycerin	2"

Note: 2½" gauges are back-connected. All other size gauges are lower-connected.
External zero adjust standard on 3½" dial size.

Dual Pressure Ranges

Pressure Code	Standard	Metric
1†	0 to 15 PSIG	0 to 1 kg/cm ²
2	0 to 30 PSIG	0 to 2 kg/cm ²
3	0 to 60 PSIG	0 to 4 kg/cm ²
4	0 to 100 PSIG	0 to 7 kg/cm ²
5	0 to 160 PSIG	0 to 11 kg/cm ²
6	0 to 300 PSIG	0 to 21 kg/cm ²
7†	0 to 600 PSIG	0 to 42 kg/cm ²

†Not available in 2" gauge

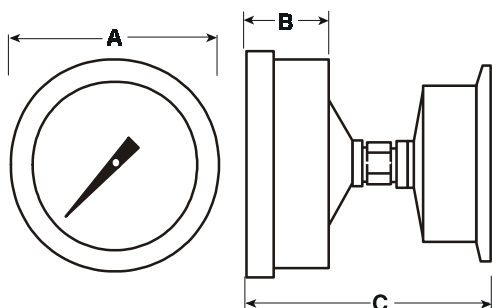

Back-Connected (Horizontal)
Dimensions

	2½" (63 mm)	
	in	mm
A	2 ⁷ / ₈	73
B	1 ³ / ₁₆	30
C	3 ³ / ₁₆	81

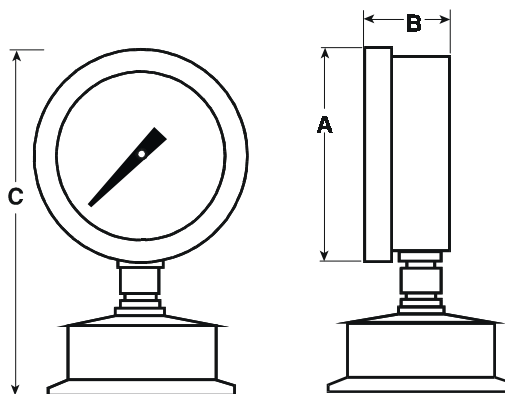

Lower-Connected (Vertical)
Dimensions

	2" (50mm)		3½" (100mm)		4½" (113mm)	
	in	mm	in	mm	in	mm
A	2 ³¹ / ₃₂	75	3 ³¹ / ₃₂	101	5 ³ / ₁₆	132
B	1 ¹ / ₁₆	27	1 ⁷ / ₃₂	31	2 ¹ / ₁₆	52
C	3 ²⁷ / ₃₂	97	5 ⁹ / ₁₆	141	7 ¹ / ₁₆	180



Tri-Clover Inc.
P.O. Box 1413
Kenosha, Wisconsin 53141-1413
PHONE: 800-242-4000
414-694-5511
FAX: 414-694-7104

E-Mail address: TCWEBMASTER@alfalaval.com
Visit our web site at www.tri-clover.com