

## ECX Actuators – Materials of Construction

### HC4 Diaphragm Valves

HC4/144/01/07.04

Item	Component	Material
1	Plug	Polyethylene
2	Cover	Si. aluminium
3	Upper spring plate	SG iron
4	Outer spring	Steel
5	Middle spring	Steel
6	Inner spring	Steel
7	Spring retaining bolt	Steel
8	Diaphragm plate	Forged steel
9	Operating diaphragm	Rubber
10	Clamp washer	Mild steel
11	Lower cylinder	Si. aluminium
12	Cyl./bonnet screw	Steel
13	Bonnet	Cast iron
14	Bonnet O ring	Nitrile
15	Bonnet/Cyl. Joint	Klingersil
16	Spindle	Stainless steel
17	Compressor	Cast iron
18	Compressor pin	Steel
19	Line diaphragm	Rubber or FE/Rubber
20	Screw cover	PE
21	Cyl./cover screw	Steel
22	Cyl./cover nut	Steel
23	Cyl./cover washer	Steel
24	Body/bonnet nut	Stainless steel
25	Body/bonnet stud	Stainless steel

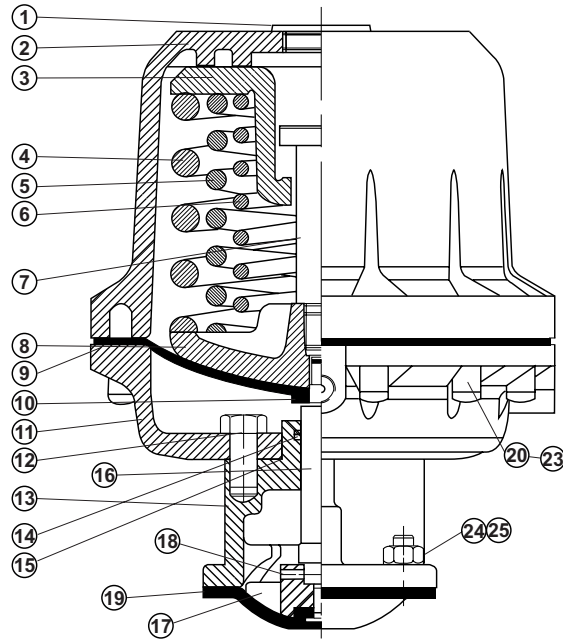

Item	Component	Material
1	Cover plug	Steel
2	Cover plug O ring	Rubber
3	Upper cylinder	Si. aluminium
4	Spindle screw	Steel
5	Screw cover	PE
6	Cylinder screw	Steel
7	Cylinder washer	Steel
8	Cylinder nut	Steel
9	Nut cover	PE
10	Diaphragm plate	Steel
11	Operating diaphragm	Rubber
12	Diaphragm plate	Steel
13	Lower cylinder	Si. aluminium
14	Cyl./bonnet screw	Steel
15	Bonnet/cyl. Joint	Klingersil
16	Bonnet O ring	Rubber
17	Bonnet	Cast iron
18	Spindle limit pin	Steel (DN150)
19	Spindle	Stainless steel
20	Compressor pin	Steel
21	Body/bonnet nut	Steel
22	Body/bonnet stud	Steel
23	Body/bonnet washer	Steel
24	Compressor	Cast iron
25	Line diaphragm	Rubber or PTFE/Rubber

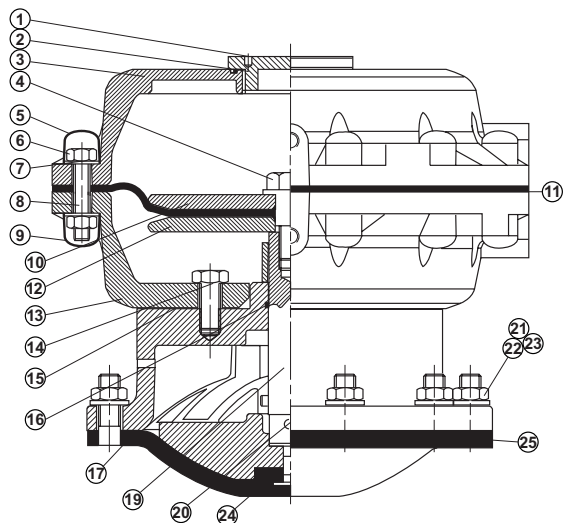

Item	Component	Material
1	Cover plug	Steel
2	Cover plug O ring	Rubber
3	Upper cylinder	Si. aluminium
4	Spindle screw	Steel
5	Clamp washer	Steel
6	Screw cover	PE
7	Cylinder screw	Steel
8	Cylinder washer	Steel
9	Cylinder nut	Steel
10	Nut cover	PE
11	Operating diaphragm	Rubber
12	Spacer ring	Si. aluminium
13	Diaphragm plate	SG iron
14	Lower cylinder	Si. aluminium
15	Spring	Steel
16	Cyl./bonnet screw	Steel
17	Bonnet	Cast iron
18	Bonnet O ring	Nitrile
19	Spindle	Stainless steel
20	Compressor	Cast iron
21	Compressor pin	Steel
22	Line diaphragm	Rubber
23	Indicator cover	Polycarbonate
24	Indicator	Nylon
25	Body/bonnet nut	Stainless steel
26	Body bonnet stud	Stainless steel

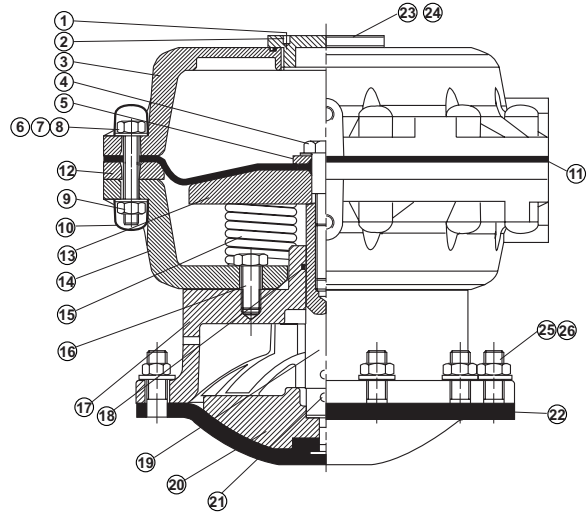

**Crane Process Flow Technologies**  
**Saunders HC4 Products**  
**9860 Johnson Road**  
**Montgomery, Texas 77316**  
**www.cranesaunders.com**  
**PH 936-588-4447**  
**Fax 936-588-8302**