

FDA500

Thermostatic Clean Steam Trap (Repairable)

Revised 9/2004

Model	FDA500
Sizes	1/2", 3/4", 1"
Connections	Clamped, NPT, Tube Weld
Body Material	Stainless Steel
PMO Max. Operating Pressure	90 PSIG
TMO Max. Operating Temperature	Saturated Steam Temperature
PMA Max. Allowable Pressure	145 PSIG up to 338°F
TMA Max. Allowable Temperature	350°F @ 132 PSIG

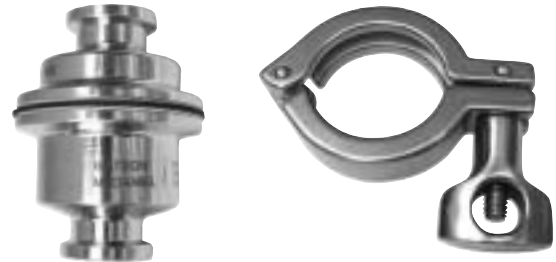

TYPICAL APPLICATIONS

DRIP, PROCESS: The FDA500 Series thermostatic steam traps are used on clean steam applications as drip traps on piping runs as well as drainage for CIP/SIP systems and various process vessels.

HOW IT WORKS

The thermostatic trap contains a welded 316L stainless steel thermal element that expands when heated and contracts when cooled. When air and condensate are present the trap is in the open discharge position. When steam reaches the trap the element expands closing the trap tightly.

FEATURES

- All wetted parts are 316L stainless steel
- Electro-polish finish of 20-25 microinches RA on internal body
- Electro-polish finish of 25-32 microinches RA on external body
- Operates close to saturation curve to minimize condensate back-up
- Completely self-draining in the vertical downward flow orientation

SAMPLE SPECIFICATION

The steam Trap shall be all 316L stainless steel thermostatic type with a balanced pressure bellows that operates close to saturated steam temperatures. Internal body parts shall have an electro-polish finish of 20-25 microinches RA internally and a 25-32 finish externally. The unit shall have a split-body sanitary clamp design for easy maintenance. Trap shall be completely self-draining when mounted vertically.

INSTALLATION

Trap is designed for installation in a vertical, downward flow orientation to ensure that the self-draining clean steam requirement is satisfied. Isolation valves should be installed for maintenance purposes. For welded installations removal of the body gasket and thermal element is necessary.

MAINTENANCE

Dirt is the most common cause of premature failure. Therefore, the upstream strainer should be periodically inspected and cleaned. For full maintenance details see Installation and Maintenance Manual.

MATERIALS

Body	Stainless Steel, AISI 316L
Gasket	Teflon/Encapsulated Viton
Element Plate	Stainless Steel, AISI 316L
Thermal Element	Stainless Steel, AISI 316L
Clamp	Stainless Steel, AISI 316L

CAPACITIES – Condensate (lbs/hr)

Orifice (inches)	Differential Pressure (PSI)					
	5	10	20	50	75	90
9/64	140	240	400	690	850	950
5/16	280	480	800	1380	1700	1900

Capacities at 10° F below saturation.

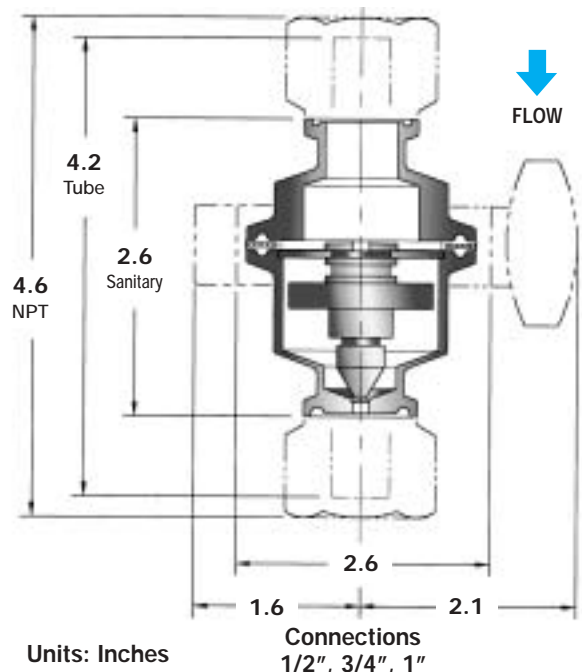

STEAM TRAPS

FDA600

Thermostatic Clean Steam Trap

Watson McDaniel reserves the right to change the designs and/or materials of its products without notice.
©2004 Watson McDaniel Company

Revised 9/2004

Model	FDA600
Sizes	1/2", 3/4", 1"
Connections	Clamped, NPT, Tube Weld
Body Material	Stainless Steel
PMO Max. Operating Pressure	110 PSIG
TMO Max. Operating Temperature	Saturated Steam Temperature
PMA Max. Allowable Pressure	145 PSIG up to 338°F
TMA Max. Allowable Temperature	350°F @ 132 PSIG

TYPICAL APPLICATIONS

DRIP, PROCESS: The FDA600 Steam Traps are used on clean steam applications as drip traps on piping runs as well as drainage for CIP/SIP systems and various process vessels.

HOW IT WORKS

The thermostatic trap contains a welded 316L stainless steel thermal element that expands when heated and contracts when cooled. When air and condensate are present the trap is in the open discharge position. When steam reaches the trap the element expands closing the trap tightly.

FEATURES

- All wetted parts are 316L stainless steel
- Operates close to saturation curve to minimize condensate back-up
- Completely self-draining in the vertical downward flow orientation

SAMPLE SPECIFICATION

The Steam Trap shall be all 316L stainless steel thermostatic type with a balanced pressure bellows that operates close to saturated steam temperatures. The unit shall have a split-body design for easy maintenance. Trap shall be completely self-draining when mounted vertically.

INSTALLATION

The trap is designed for installation in a vertical, downward flow orientation to ensure that the self-draining clean steam requirement is satisfied. Isolation valves should be installed for maintenance purposes. For welded installations removal of the body gasket and thermal element is necessary.

MAINTENANCE

Dirt is the most common cause of premature failure. Therefore, the upstream strainer should be periodically cleaned. For full maintenance details see Installation and Maintenance Manual.



MATERIALS

Body	Stainless Steel, AISI 316L
Thermal Element	Stainless Steel, AISI 316L
O-Ring, FDA Grade	Teflon Coated Silicone/FEP
Nuts & Bolts	Stainless Steel, AISI 316L

HOW TO ORDER

Refer to the capacity chart to determine which model is required to satisfy the condensate load.

CAPACITIES – Condensate (lbs/hr)

Condensate Temp Below Saturation	Differential Pressure (PSI)						
	1	5	10	20	50	75	110
10 °F	32	105	175	290	615	805	1160
20 °F	42	115	225	440	1060	1500	1850
Cold Water	735	1070	1375	1900	3100	3500	4600

